



Deep Bed Filter

Top Mount Series with Manual Valve



USER MANUAL

NOTE: Stop the pump before changing the valve position!



**Please read and follow this MANUAL before install
and use the filter!**

1. Deep Bed Filter Parameters

Model	Tank Size	A (mm)	B (mm)	D (mm)	Valve Connections	Filter Media (kg)			Volume (Liter)	Top Opening	Flow Rate (m3/h)
						Sand	Carbon	Cation Resin			
HT-DB12	Φ12"*48", 2.5"	1225	1005	300	1" / 32mm	92	30	50	83	2.5" thread	1.6~2.2
HT-DB13	Φ13"*54", 2.5"	1390	1350	325	1" / 32mm	110	37	63	99	2.5" thread	2.0~2.5
HT-DB14	Φ14"*65", 2.5"	1650	1625	350	1" / 32mm	150	50	90	113	2.5" thread	2.5~3.0
HT-DB16	Φ16"*65", 2.5"	1650	1625	400	1" / 32mm	200	65	116	179	2.5" thread	3.2~4.5
HT-DB21	Φ21"*62", 4.0"	1842	1500	525	2" / 63mm	325	108	195	270	4" thread	4.5~6.0

Features:

- Max. operating pressure: 100psi / 7bar
- Max. water temperature: 50°C (122°F)
- Simple operation
- Automatic or Manual Valve options
- Suggested media sizes: 0.5mm – 0.8mm
- Easy set up slim design



Interior design of the tanks
HT-DB12 / HT-DB16



Interior design with laterals
for the tank HT-DB21

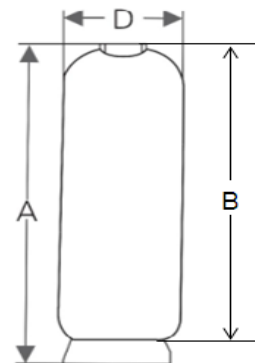

Function

Hidrotermal Deep Bed or Multimedia Filters are designed for filtering incoming water from water well or any other water supply for domestic or commercial usage. Undesired particles like rust, sand, dirt and other impurities found in water are trapped by the filter bed, offering crystal clear filtered water for domestic and light commercial usage.

Our filters can be filled with different filter media such as sand, gravel, activated carbon or resin. Or even combined multiple medias in the same tank to ensure better filtration and desired water quality.

2. Manual Filter Valve Technical Parameters

Model	Intel/Outlet		Drain		Flow rate(m ³ /H)	Base	Center pipe	Suitable tank
HT-F56A	1"F	32mm	1"F	32mm	4	2.5"-8NPSM	1.05"OD	6"-12"
HT-F56D	2"F	63mm	2"F	63mm	10	4" -8UN	1.5" D-GB	10"-24"

Noted:

- 1) F-Female; M-Male; OD-Outer diameter; D-GB-Chinese standard
- 2) The capacity of treated water is relate to the designed flow rate, inlet pressure and filter materials, the above chart for reference only.

Warning:

The filter is operating under high pressure. Air can enter the system and become pressurized when any part of the circulating system (e.g filters, valve, etc.) is serviced. Hence, release the pressure before removing the valve. Failure to do so may result in severe injury, death or property damage. Turn pump of tap off before changing valve position. Do not remove valve when there is incoming water flow.

3. Installation Guide:

Before installation, read all those instructions completely. Then obtain all materials and tools needed for installation. The installation of product, pipes, should be accomplished by professional to ensure the product can operate normally. Perform installation according to the relative pipeline regulations and the specification of Inlet, Outlet, Drain Outlet.

3.1 Device location

- 1) The filter should be located close to drain.
- 2) Ensure the unit is installed in enough space for operating and maintenance.
- 3) The unit should be kept away the heater, and not be exposed outdoor. Sunshine or Rain will cause the system damage.
- 4) Do not install the filter, drain pipeline in circumstance which temperature may drop below 5 °C (41°F), or above 50 °C (122°F).
- 5) One place is recommended to install the system which cause the minimum loss in case of water leaking.

3.2 Installation

- 1) If the valve has been previously installed, un-tighten the Multi Port Valve in an anti-clockwise direction and remove from the filter tank. Check laterals for any damage.
- 2) Cap the internal pipe with a plastic cap to prevent sand from entering it.
- 3) Half fill the tank with water.
- 3) Ensure the media is spread evenly when pouring into the tank.
- 4) Position the central pipe firmly to the center of the tank when viewed from top. When central pipe is firm in the center, continue to pour the remaining volume of media into the tank until approximately 70% of the tank level.
- 5) Install the top distributor to the valve and insert the riser tube into control valve.
- 5) Carefully remove all the filter media and debris away from the threads of the filter tank.
- 6) Thread the valve into the filter tank and tighten the pipe joints at various ports.
Hand tighten only. Do not over-tighten the joints.

Note:

- a. The length of riser tube should be neither higher 2mm nor lower 5mm tank top opening height, and it's top end should be rounded to avoid damage of O-ring inside the valve.
- b. Avoid floccules substance together with resin to fill in the tank.
- c. Avoid O-ring inside control valve falling out while rotating it on the tank.

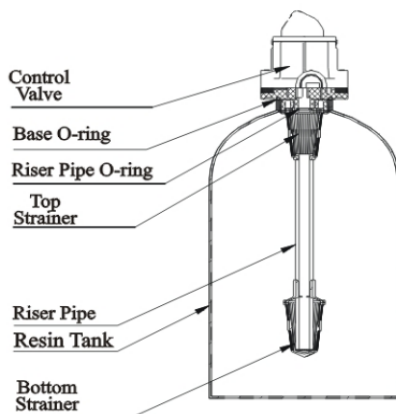

Figure 1-1

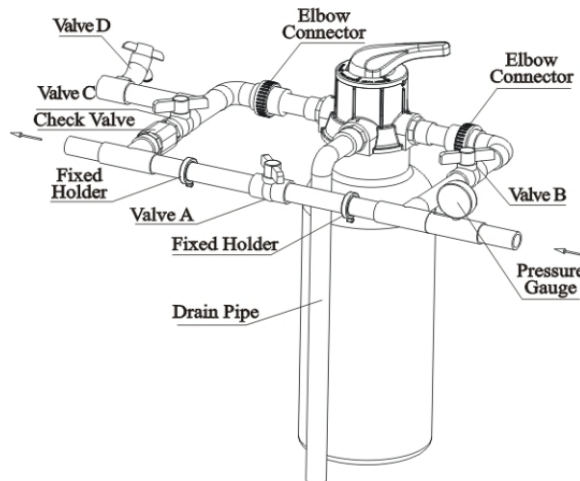

Figure 1-2

3.3 Pipeline connection

- a. As Figure 1-2 shows, install a pressure gauge in water inlet.
- b. Install valve A, valve B, valve C and valve D in inlet pipeline, outlet pipeline, the middle of the inlet and outlet pipeline. Valve D is sampling valve.
- c. Install a check valve in water outlet.
- d. Inlet pipeline should be in parallel with outlet pipeline. Support inlet and outlet pipeline with fixed holder.

Note:

If making a soldered copper installation, do all sweat soldering before connecting pipes to the valve. Torch heat will damage plastic parts.
When turning threaded pipe fittings onto plastic fitting, use care not to cross thread or broken valve.

3.4 Install drain pipeline

Directly connect the outlet with the rigid pipeline, such as UPVC, etc.

Note:

- a. Control valve should be higher than drain, and be better not far from the drain hose.
- B. Be sure not to connect drain with sewer, and leave a certain space between them, avoid wastewater be absorbing to the water treatment equipment, such as showed in the Figure 1-3.

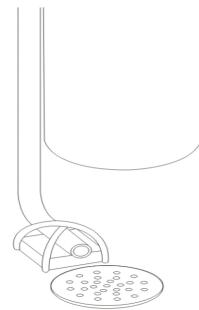
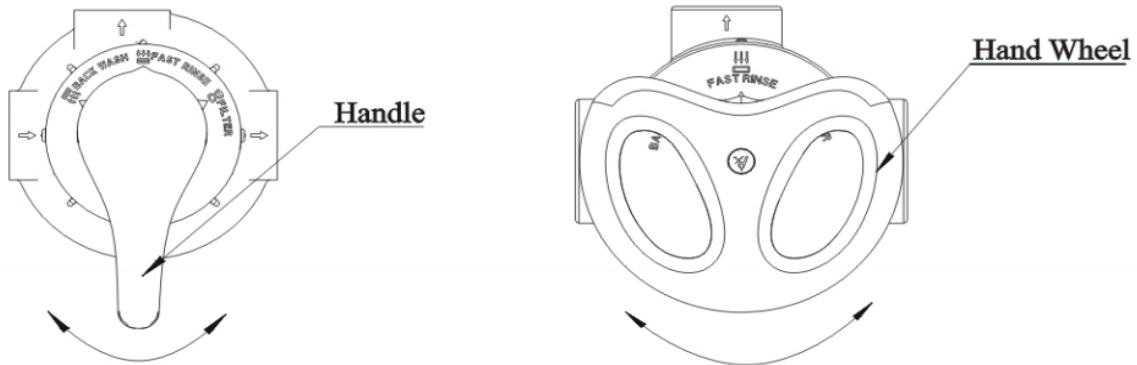

Figure 1-3

4. Usage

4.1. Hand Wheel

This series of control valve is operated by hand wheel to realize service, backwash and fast rinse. As the following pictures show:(The appearance for reference only.)



Note: The handle can not be rotated beyond the limit position, please do not flip it up and down.

4.2. Manual Filter Valve Operation

Valve Position	Figure	Function
FILTER		In service (filtration) status, normal filtration
FAST RINSE		In Fast rinse status, flush out dirt after backwashing
BACK WASH		In backwash status, cleans the filter media by reversing the flow

1) Importance of Backwash

After a period of prolong filtering, the filter will be clogged by debris and dirt's. This will reduce the performance of the filter. To maintain the optimal performance, regular backwashing is essential to get rid of the undesired material in the tank.

2) Condition of Backwash

To determine the right time to perform backwash, refer to below conditions:

- a. The flow rate through the filter bed decreases.
- b. The quality of the water after filtration is not up to standard.

It is suggested to perform backwashing once every 2 weeks for domestic usage.

4.3 Flow Chart

Take HT-F56A for example, the working theory of the other filter valves are the same as HT-F56A.

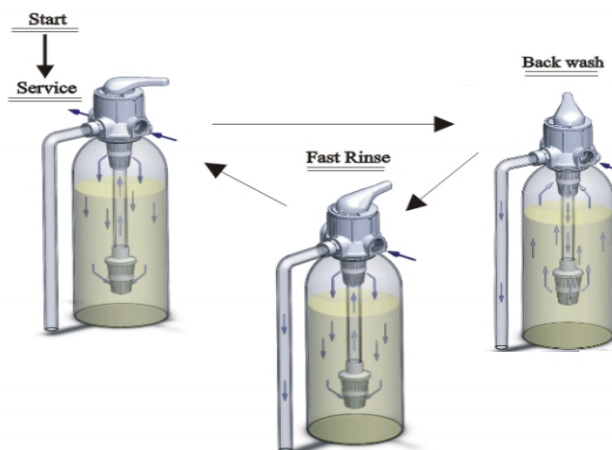

5. Trial Running

5.1. Fix the valve on the tank, connect all the pipelines, then do as follows:

- 1) Close the inlet valve B & C, and open the bypass valve A. After cleaning the impurities in the pipe, close the bypass valve A (As figure 1-2 shows, the same as below).
- 2) Switch hand wheel to Backwash position. Slowly open the inlet valve B to 1/4 position, making the water flow into the tank; After water stopping flowing, open outlet valve C, then can hear the sound of air-out from the drain pipeline. After all the air is our of pipeline, then close outlet valve (Check if there is leakage. If it is, solve it immediately.) Open inlet valve B completely and clean the impurities in the resin tank until the outlet water is clean. It will take 8~10 minutes to finish the whole process.
- 3) Complete Backwash, switch hand wheel to Fast Rise positon start fast rinse about 10~15minutes.
- 4) Take some water for testing, and stop fast rinse if qualified. Then making the control valve return to Service and start to running.

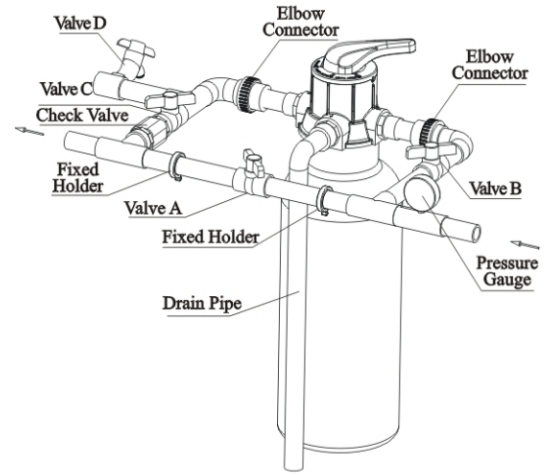

Figure 1-2

5.2. Instruction:

- 1) If the water is too fast, the media of the tank will be lost, if the water is slowly, should be able to hear the sound of air slowly discharged from the drain.
- 2) After replace the filter, follow the "Trial Running" step "b" to operate, discharge air in the filter layer.
- 3) In the process of trial run, check the status of water and there should be no filter leakage.
- 4) According to the complete equipment supplier's recommendations to set the residence time in each positions.

6. Trouble Shooting Guide

Problem	Cause	Solution
1. Filter doesn't work	Control Valve broken	Change Control valve
2. Filter supply raw water.	A. Bypass ball valve is opening	A. Close bypass ball valve
	B. Rinse pipe leakage	B. Make sure riser pipe and riser pipe o-ring is not cracked.
	C. Internal of valve body leakage.	C. Change valve body.
3. Pressure lost	A. Iron in the water supply pipe.	A. Clean the water supply pipe.
	B. Iron mass in the filter.	B. Clean valve and increase frequency of washing.
4. Filter material expel from drain line.	A. Air in water system.	A. Assure the exhaust system in normal condition
	B. Backwash Intensity is too large.	B. Reduce the backwash intensity.
	C. Strainer broken.	C. Replace new strainer.
5. Drain flows continuously	A. Internal valve leakage.	A. Check and repair valve body or replace it.

7. Warning

- ⚠ 1. THE FILTER OPERATES UNDER HIGH PRESSURE. WHEN ANY PART OF THE CIRCULATING SYSTEM, (e.g. FILTERS, VALVE, etc.) IS SERVICED, AIR CAN ENTER THE SYSTEM AND BECOME PRESSURIZED. PRESSURIZED AIR CAN CAUSE THE VALVE TO BE BLOWN OFF WHICH CAN RESULT IN SEVERE INJURY, DEATH OR PROPERTY DAMAGE.
- ⚠ 2. TURN PUMP OR TAP OFF BEFORE CHANGING VALVE POSITION.
- ⚠ 3. DO NOT REMOVE VALVE WHEN THERE IS INCOMING WATER FLOW.



8. Valve Body Components

8.1 Valve Replacement Parts-HT-F56A

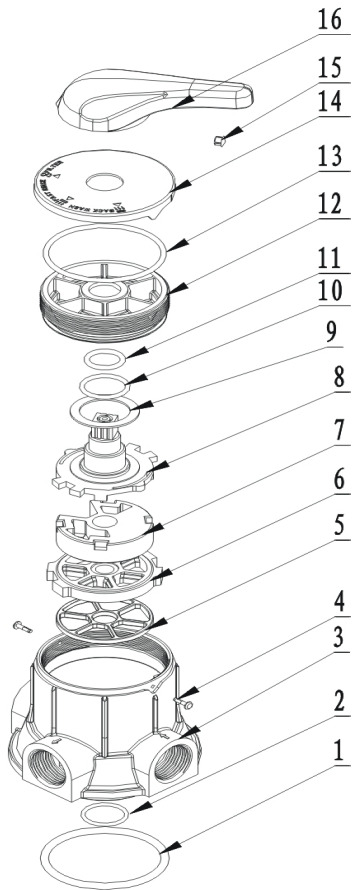

Key No.	Product Description	Qty
1	O-ring	1
2	O-ring	1
3	Valve Body (ABS + GF10)	1
	Valve Body (PPO + GF20)	1
4	Plastic Pin	2
5	Seal Ring	1
6	Fixed Disk	1
7	Moving Disk	1
8	Shaft	1
9	Anti-friction Washer	1
10	O-ring	1
11	O-ring	1
12	Fitting Nut	1
13	O-ring	1
14	Decorative Cover	1
15	Decorative Button	1
16	Handle (Metal)	1
	Handle (Plastic)	

8.2 Valve Replacement Parts-HT-F56D

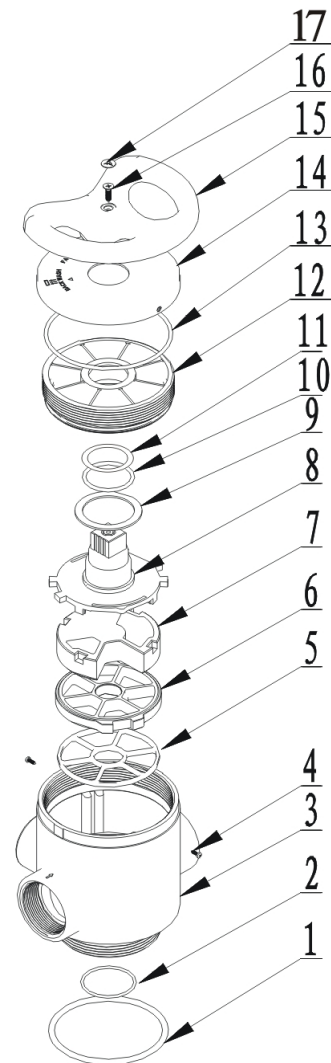

Item No.	Product Description	Qty
1	O-ring	1
2	O-ring	1
3	Valve Body	1
4	Screw, Cross	2
5	Seal Ring	1
6	Fixed Disk	1
7	Moving Disk	1
8	Shaft	1
9	Anti-friction Washer	1
10	O-ring	1
11	O-ring	1
12	Fitting Nut	1
13	O-ring	1
14	Decorative Cover	1
15	Handle	1
16	Screw, Cross	1
17	Brand	1





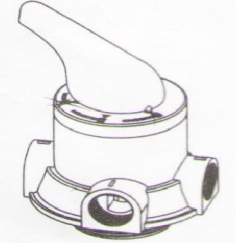
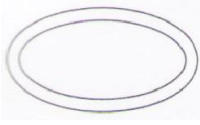

9. Manual Filter Valve Packing list

When open the valve box, please check the following parts.

1) HT-F56A Valve

Description	Picture	Quantity	Remark
Control Valve		1PC	This picture is for reference only
User Manual		1PC	
Spare parts Kit include following parts			
Base Seal Ring(73*5.3)		1PC	
1" Washer ($\phi 30 \times \phi 24 \times 3.3$)		3PCS	

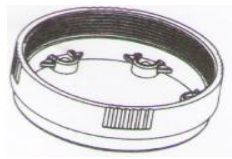
2) HT-F56D Valve

Description	Picture	Quantity	Remark
Control Valve		1PC	This picture is for reference only
User Manual		1PC	
Spare parts Kit include following parts			
Base Seal Ring (104.6*5.7)		1PC	
Threaded Top Strainer Connector		3PCS	
Tapping Screw ST3.9*19		5PCS	